



«Cultural Heritage e Merchandising Museale»

Progetto in collaborazione
Fra
Il Museo Archeologico Regionale
Antonio Salinas di Palermo

Ed il Liceo Artistico
E. Catalano di Palermo

a.s. 2015/16

Documentazione degli elaborati della
Mostra didattica
a cura della prof.ssa Lucia Corsaro



RELAZIONE DEL REFERENTE PER LA SCUOLA
(prof.ssa Lucia Corsaro)

Quando l'Architetto Patrizia Grasso ha proposto il progetto alla nostra scuola ne sono rimasta entusiasta poiché il progetto «Cultural Heritage e Merchandising Museale» costituisce, indubbiamente, una proposta formativa che si integra perfettamente con il Profilo Professionale e Culturale a cui fa riferimento un Liceo Artistico. Il progetto di didattica museale proposto è innovativo: guarda, infatti, alla possibile costruzione di figure professionali del futuro, come l'esperto in merchandising museale; avvicina i giovani al «museo» come luogo non esclusivamente destinato alla conservazione; assume la metodologia dell'alternanza scuola-lavoro (formazione specifica, progettazione, didattica laboratoriale, allestimento di una mostra e workshop finale); porta gli studenti a confrontarsi con un compito di realtà. E' un progetto molto complesso, sia sul piano organizzativo sia sul piano didattico: entrano infatti in gioco le logiche organizzative di due realtà istituzionali diverse, chiamate per loro natura a collaborare, e si richiede a giovani in formazione di progettare e realizzare individualmente oggetti per il Merchandising Museale prendendo spunto dallo studio e dal rilievo di reperti, dando a ciascuno studente la responsabilità di sviluppare tutto l'iter progettuale sino alla realizzazione di un manufatto. Gli studenti quindi non solo si sono trovati di fronte a richieste di alto livello sul piano delle competenze di indirizzo, ma hanno dovuto mettere in campo e lavorare su competenze chiave di cittadinanza: la capacità a saper sviluppare un'idea, di darle forma, pur tendendo presente il reperto studiato ed il contesto a cui fa riferimento; la capacità di illustrare e documentare il lavoro personale; la capacità di saper giustificare le scelte progettuali; la responsabilità di portare a termine un compito nel rispetto dei tempi; la capacità di collaborare e di saper sostenere un confronto. Alla luce dei risultati raggiunti in questa prima annualità, è quindi auspicabile che il percorso di collaborazione iniziato con il Museo possa essere portato avanti, apportando anche modifiche e miglioramenti in corso d'opera, con l'obiettivo che ogni studente possa raggiungere i migliori risultati possibili affinando capacità e competenze.

Prof.ssa Lucia Corsaro



**Classe 3[^]H del Liceo Artistico
Eustachio Catalano di Palermo**

**Docenti tutor
G. Castronovo
M. Catalano
D. Iovino**



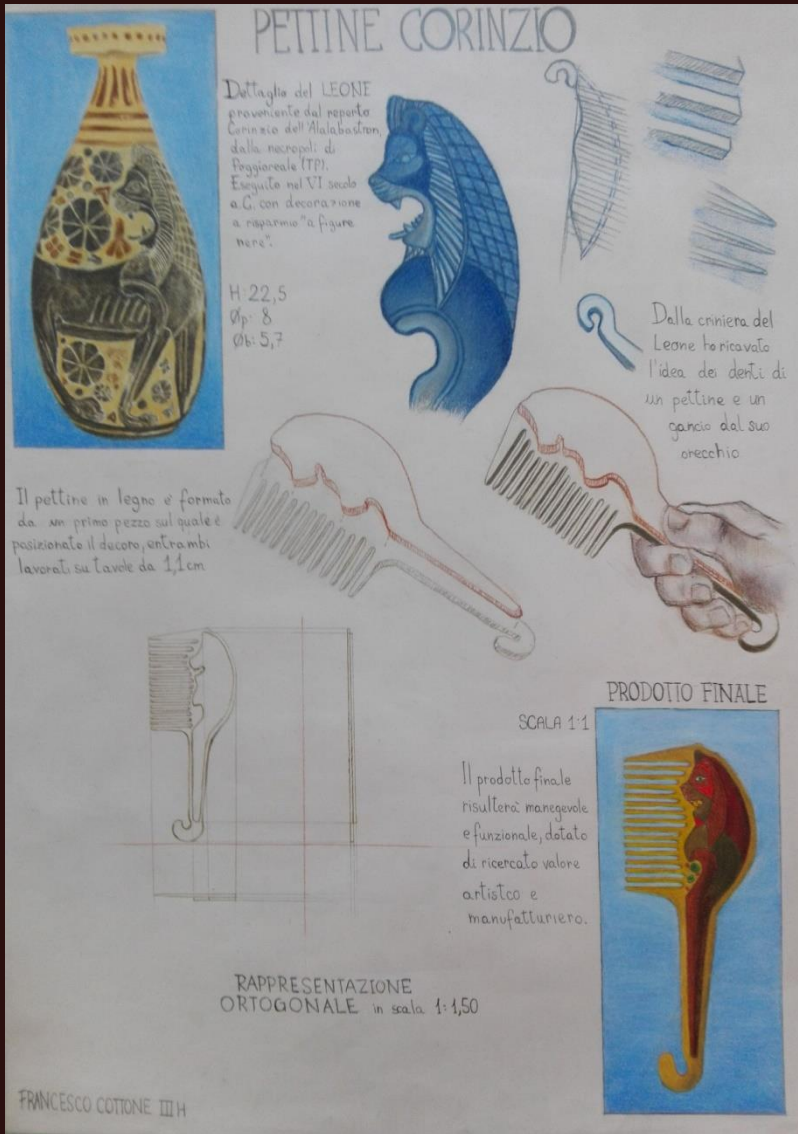

Pettine corinzio
Francesco Cottone classe 3[^]H



Portachiavi con testa leonina
Giorgia Polizzi classe 3^H



Magneti
Giulia Argano classe 3^H

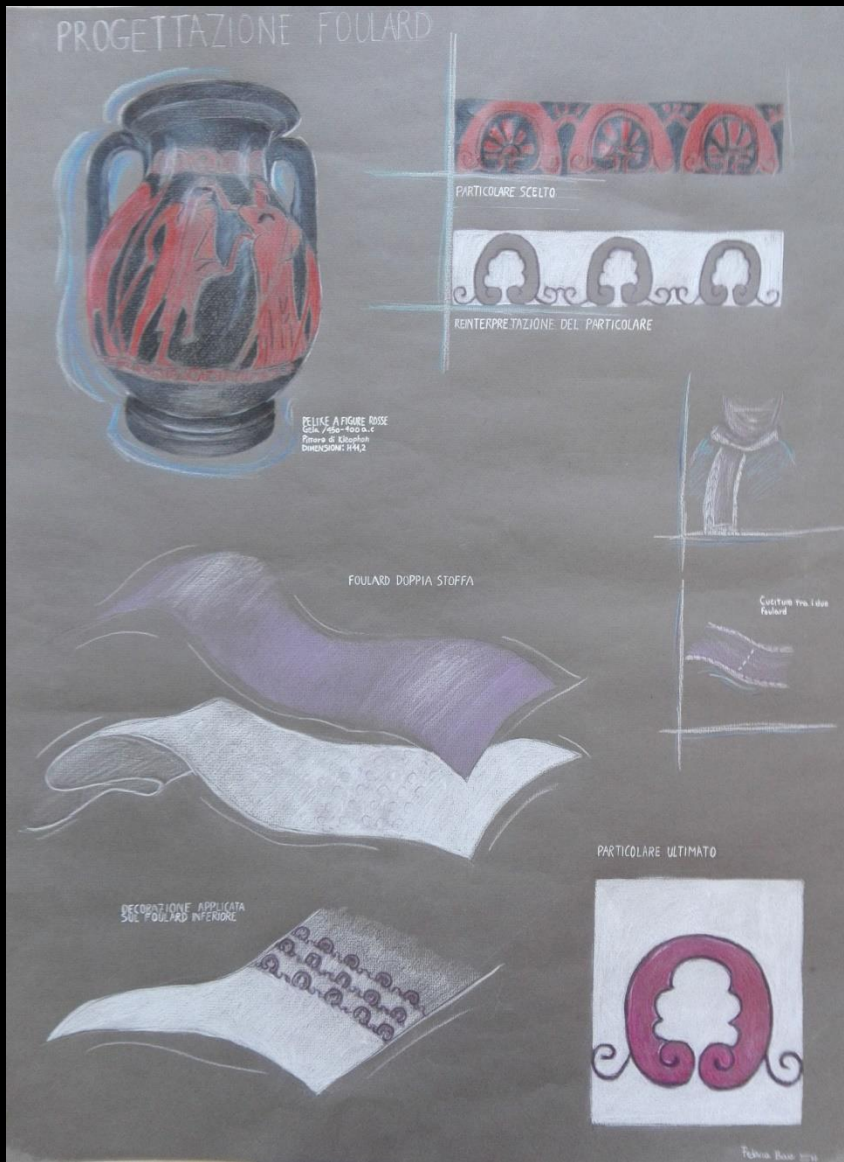

Foulard
Federica Bova classe 3^H



Ventaglio
 Riccardo Russo classe 3^H

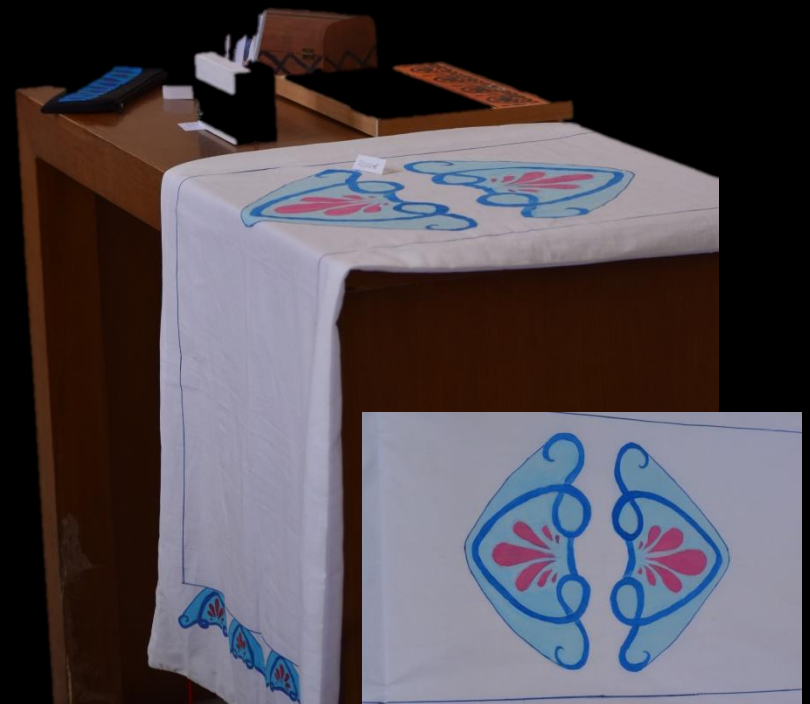
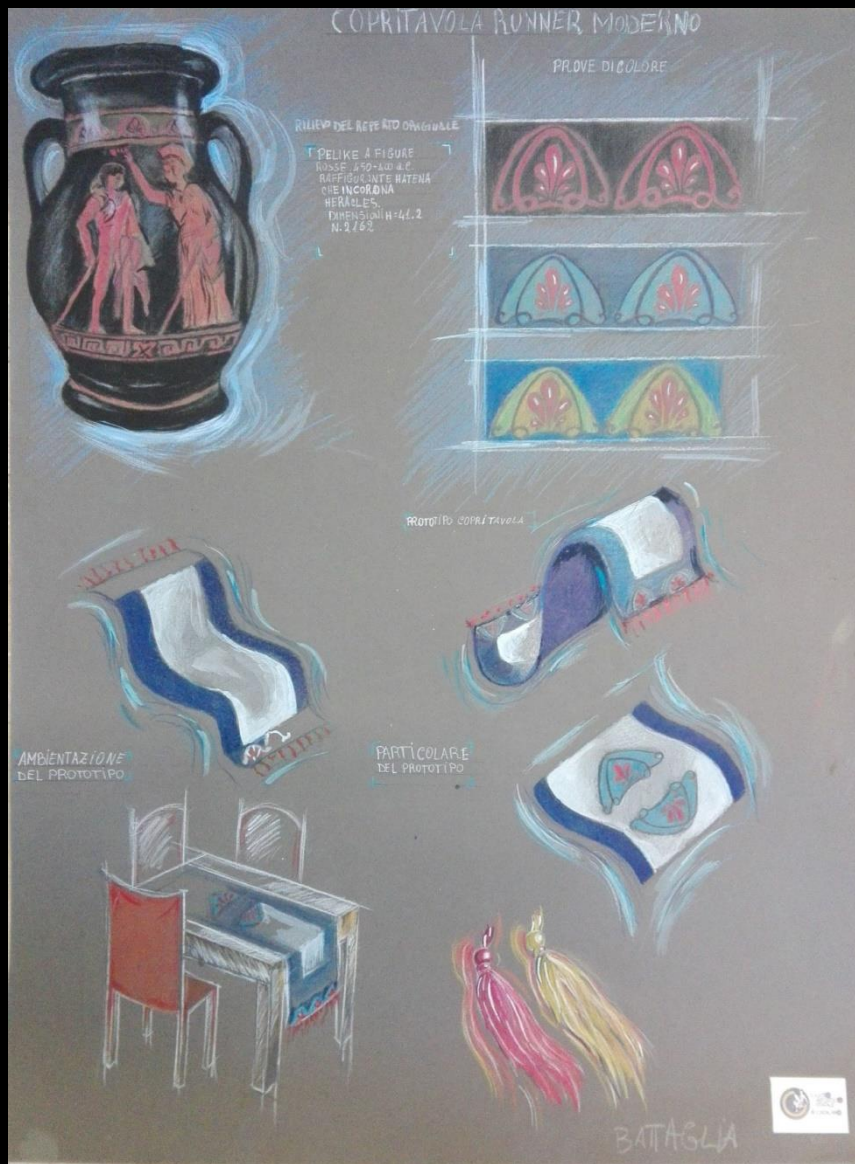

Copritavola
Federico Battaglia classe 3^H

APPENDICHIAVI



PELLE FIGURE ROSSE
DEI LONGO & C.
STORIA DI MICRONI
CANTINA 4-112



DECOMPOSIZIONE IN APPENDICHI
USO PELLE FIGURE ROSSE



APPENDICHI IN METALLO
LACCATO BIANCO



APPENDICHIAVI, SCALA 1:2
DECORAZIONE GRECA

Simona Rizzo III H



Appendichiavi
Simona Rizzo classe 3^H



DECORAZIONE ESTRAPOLATA

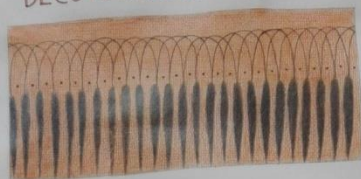

DECORAZIONE REINTERPRETATA

AGRIGENTO
500-450 a.c.
PITTORE DI BOREAS
RAFFIGURANTE HADES CHE INSEGUE UNA DONNA
REPERTO N° 2103 CRATERE A COLONNETTE A FIGURE ROSSE

HO REALIZZATO QUESTO PORTAPENNE IN
LEGNO DI ABETE PERCHÉ RITENUTO UN MATERIALE
ECOLOGICO. È UN MODELLO A STILOFORD,
PER IL COLORE HO UTILIZZATO UN MORDENTE
A BASE D'ACQUA COLOR NOCE ANTICO PER
RICHIAMARE IL COLORE DELLE DECORAZIONI
SUL VASO.

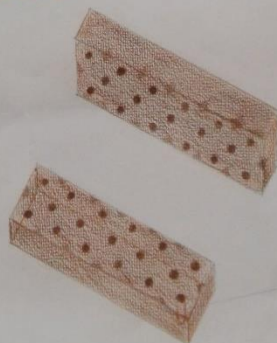
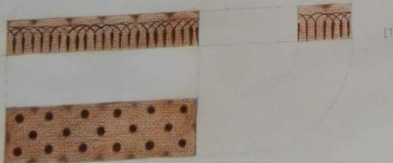

4/12
h=30cm, L=25cm, larg. 6cm.

8cm x 2
12cm

LUCIA POLIZZI 3 H.



Portapenne
Lucia Polizzi classe 3^H

LEKYTHOS ARABALICO
A FIGURE ROSSE

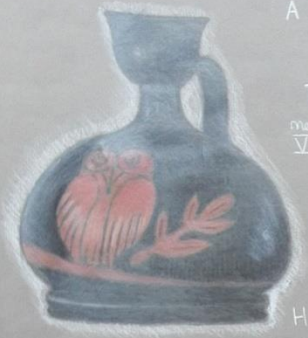

Terracotta di Culti,
metropoli est, tomba XXXI
V sec. a.C.



H 7,7, Ø 6,2

ASSONOMETRIA



PRODOTTO FINALE



- Panno seni marrone
- Panno seni giallo
- Panno seni bianco
- Panno seni nero



Borsa in panno
Asia Cusimano classe 3^H

LEKYTHOS ARIBALLICA A FIGURE ROSSE

DECORAZIONE



MANUFATTO GRECO DEL V SECOLO A.C.

LUOGO DI RITROVAMENTO=NECROPOLI EST, TOMBA XXXI

DIMENSIONI=H 7,7; Ø 6,2 cm

PROTOTIPO

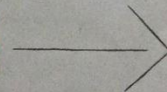

COLLANA CON CIONDOLO A FORMA DI GUFO

MATERIALE=LAMINA DI ALLUMINIO, CORDA

DIMENSIONI=3,5 X 5 cm ; 0,5 mm di SPESORE



MARRONE



AZZURRO



NERO



VIOLA



ARANCIONE



Costa, Giorgia 3M

Ciondolo
Giorgia Costa classe 3^H

PORTAFOGLIO GRECO



LEKYTOS A FIGURE NERE
BONO DAZZA DELLA
VEDUKA
SCENA DELL'INASTIMBA
CON LE ANNE E OKROS
EUS-475 a.c.
MANIERA DEL PITTORE
DI PRAXILIS
OPERATORI: dora 9.8
H. 18.1



DECORAZIONE ORIGINALE DEL
REFERTO E STUDIO CROMATICO



DECORAZIONE SCELTA DA APPLICARE
ALL'OGGETTO



REALIZZAZIONE DEL PROTOTIPO
CARTACEO IN SCALA 1:1
VISIONE INTERNA ED
ESTERNA DELL'OGGETTO

PROIEZIONE ORTAGONALE

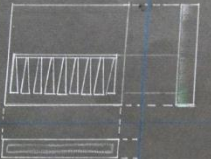

REALIZZAZIONE
DEL PROTOTIPO
FINALE IN SCALA
1:1



Portafoglio greco
Riccardo Vitale classe 3^H

OROLOGIO DA PARETE in legno

Le figure degli animali sono ritratte da:

Kilix a figura nera
 Provenienza ignota
 metà del VII sec. a.e.
 lato A e B: toro tra due felini
 alt. 14,5 - diam. 24



chiamato in 83

Balsamo Sara 2014

TAVOLA PROGETTUALE



PARTICOLARE PEINTERPETRO ULTIMATO



Lekythos asibellia a fig. uccello

Provenienza ignota
 metà del VII sec. a.e.
 lato A e B: toro tra due felini
 alt. 14,5 - diam. 24



PROVE COLORE



PROTOTIPO

Balsamo Sara 2014

Orologio da parete e maglietta
 Sara Balsamo classe 3^H



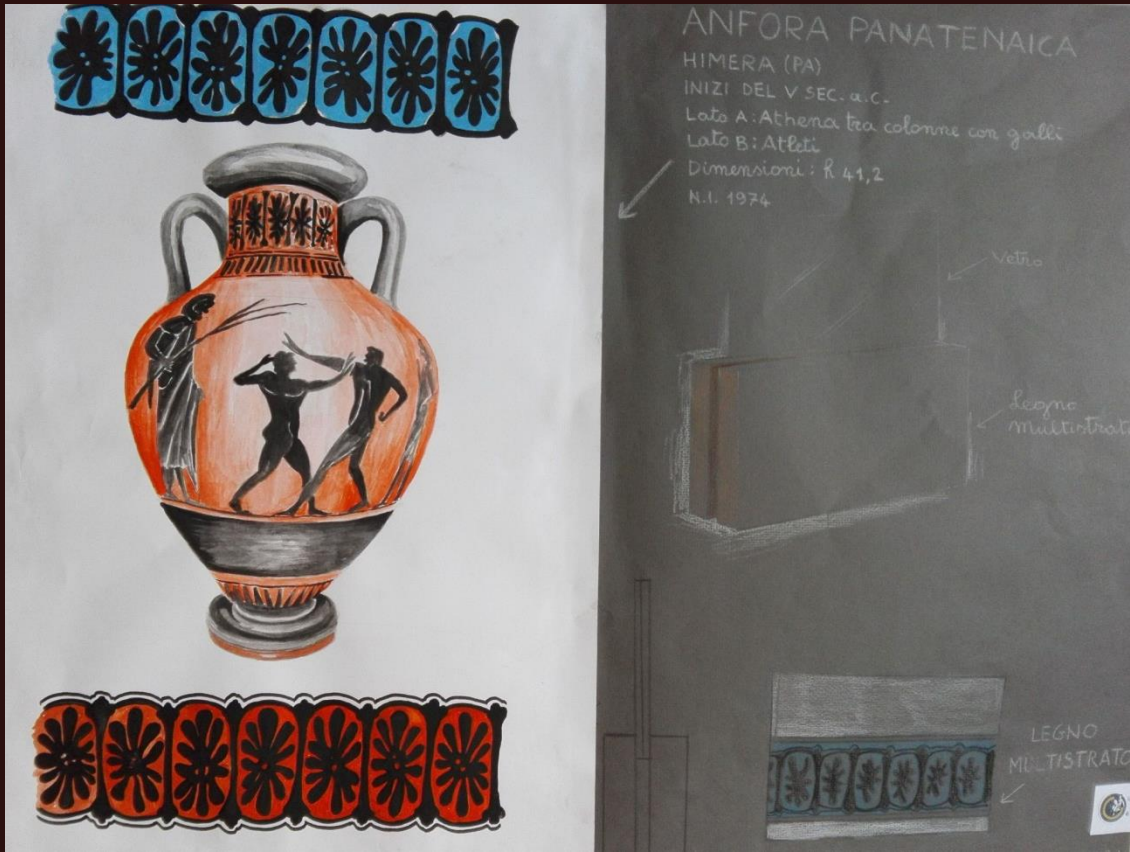

Portafotografia
Silvia Angelica classe 3[^]H

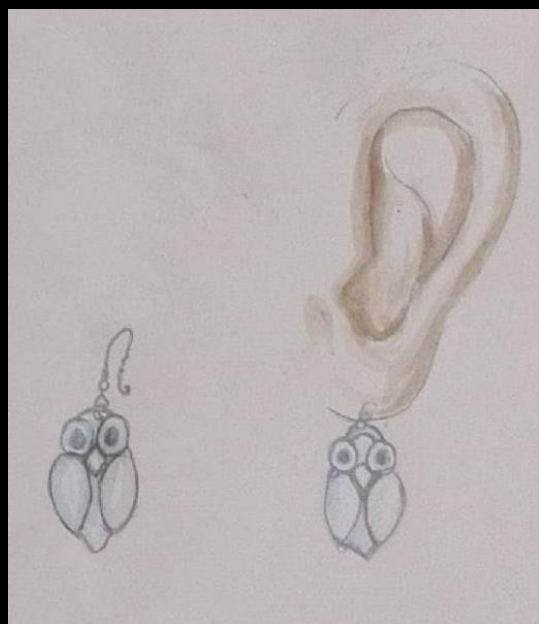
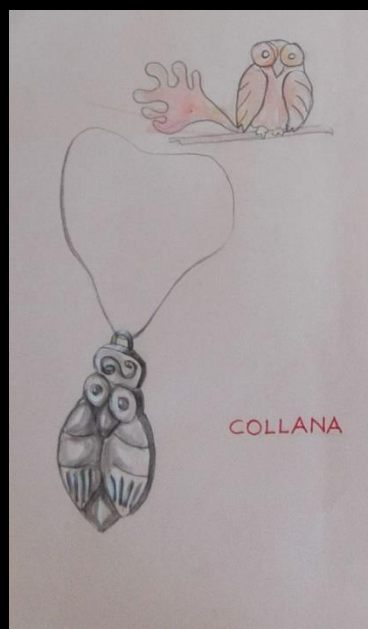

Parure
Mendola classe 3^H



Segnalibri
Giovanni Puccio classe 3^H



Portafotografia
 Cristina Cicala classe 3^H

PAPILLON A TERESA



SCODELLA A ORECCHIE A LUSTRO METALLICO
Palermo, Scavi Palazzo Chiamonte
(Stren) (Scavi Falzone 1973)
Produzione valenzana del xv secolo
Dimensioni: H. 6, ø 12, 5 (con anse 18)
N.I. 27694

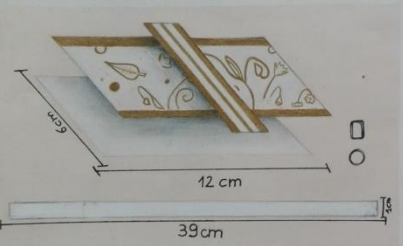

Studio del papillon, realizzato con della stoffa di cotone, decorata con dei colori per stoffa



Papillon
Teresa Taormina classe 3^H



**Classe 3[^]F del Liceo Artistico
Eustachio Catalano di Palermo**

**Docenti tutor
C. G. La Porta
D. Iovino
M. Sanfilippo**



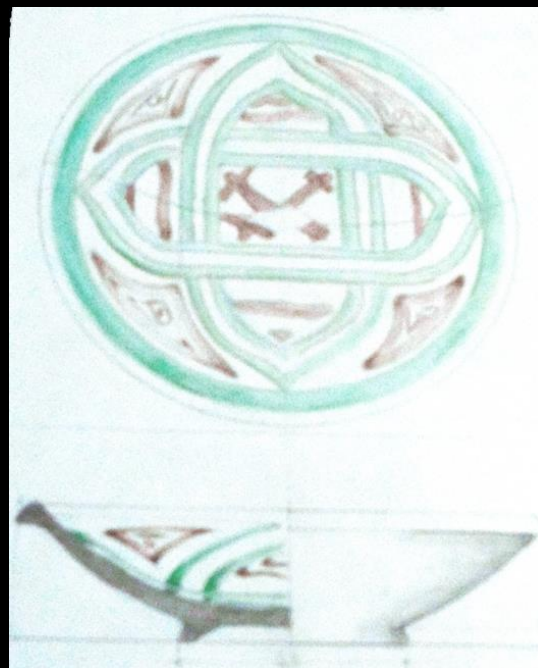
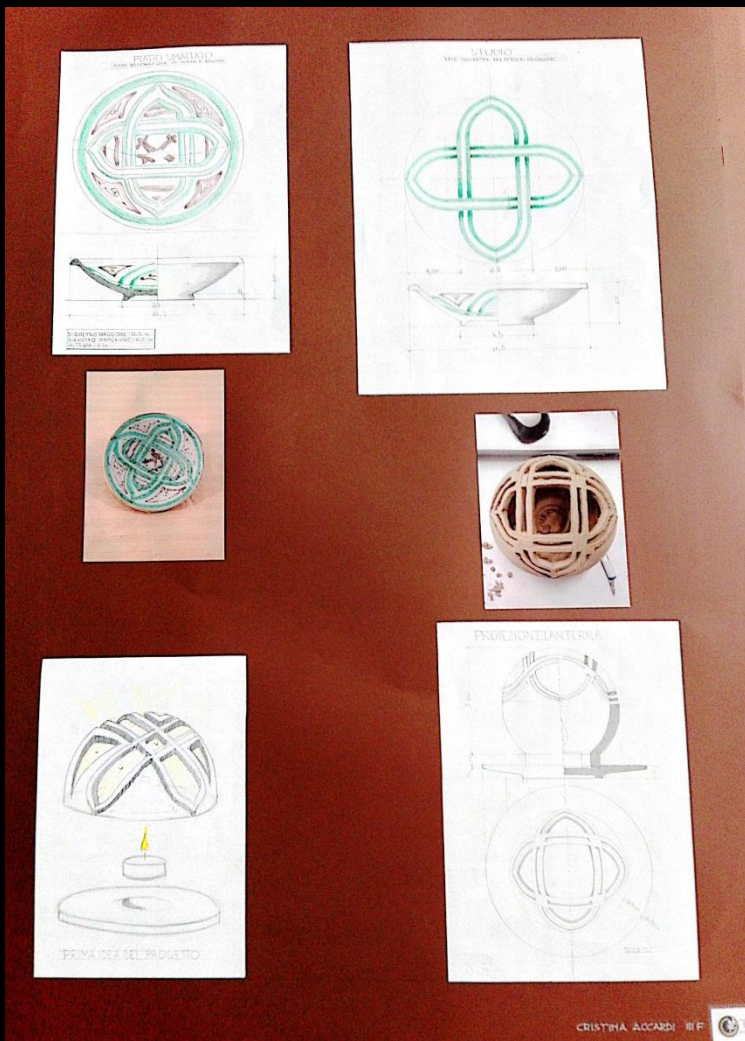

Lanterna
Cristina Accardi classe 3^F Design

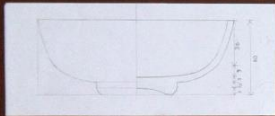
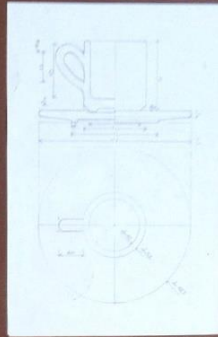
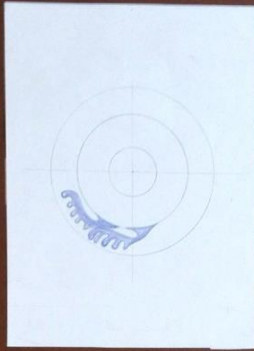

BOTTIGLIA DECORATA IN BLU DEL FAVONE (SCALD. FALCONE 1973) PRODUZIONE VALENTINA DEL 2002
 PRODOTTO DA DIMENSIONI N. TRIDIMENSIONALI SI SCELGONO IL PUNTO DI PARTENZA CON L'ARRETTA SU UNA
 LINEA TANGENTE ALLA CURVA DEL CILINDRO PER IL PUNTO DI PARTENZA DELLA LINEA DEL CILINDRO
 SECONDO LA TIRATA DEL CILINDRO ALLA SCELTA DELLA LINEA FINALE
 IL QUANTO CHE RIFUGGE LO STUO PRODOTTO TRIDIMENSIONALE IN COORDINAZIONE CON LE
 CURVE DEL CILINDRO E ALTRI PROFILI (CICLONI) SECONDO LA LINEA

GIUGIA GUERRERI 2002

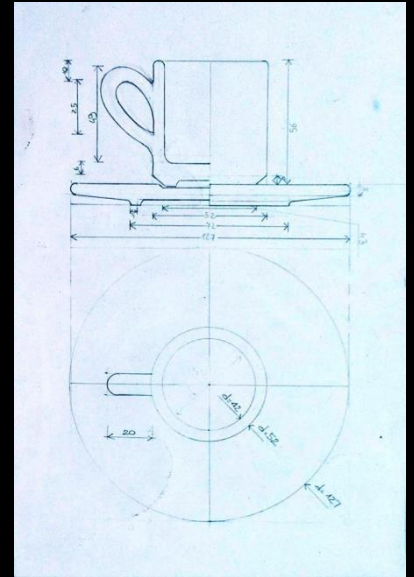

Tazzina
Giorgia Guerrieri classe 3^F Design

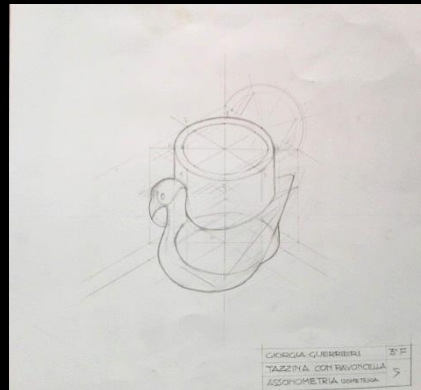

GIUGIA GUERRERI 2002
 TAZZINA CON FAVONELLA
 ACCOMPAGNATA

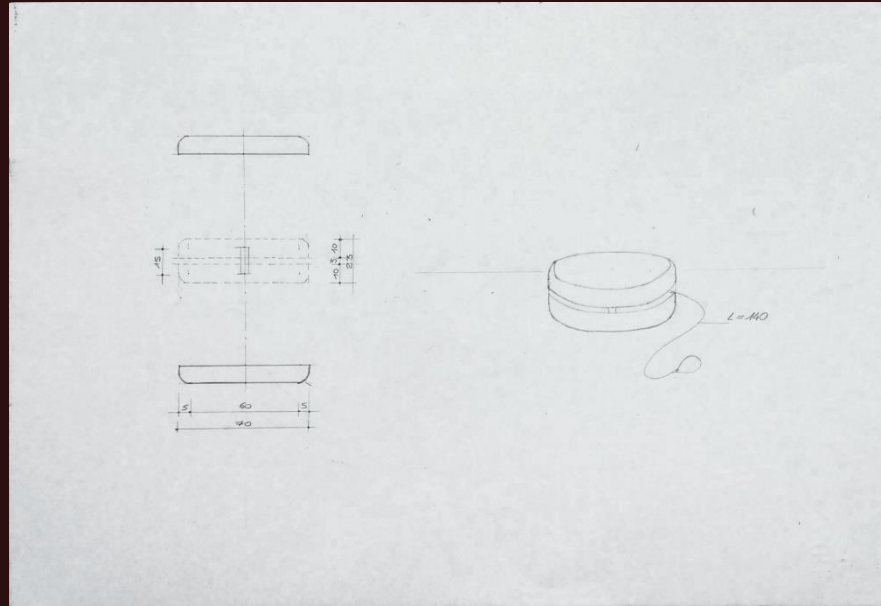
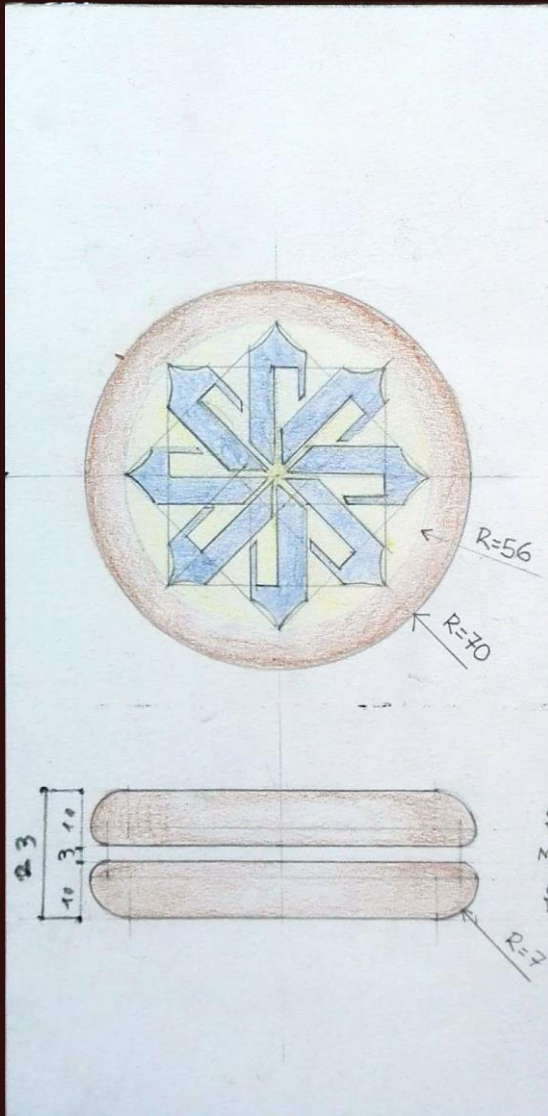

Yoyo
Giuseppe Fiducia classe 3[^]F Design

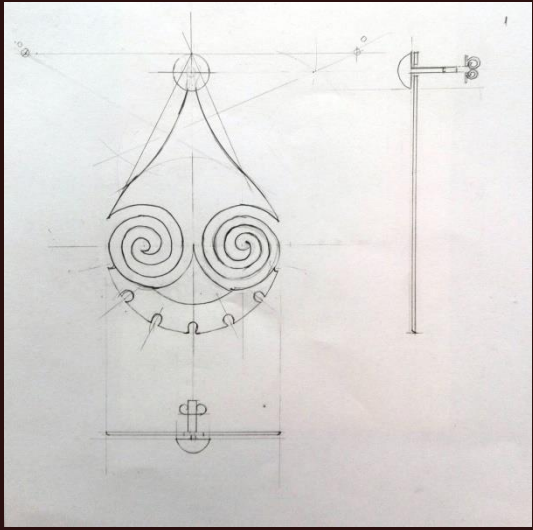

Orecchini
 Maria Concetta Lentini classe 3^F Design

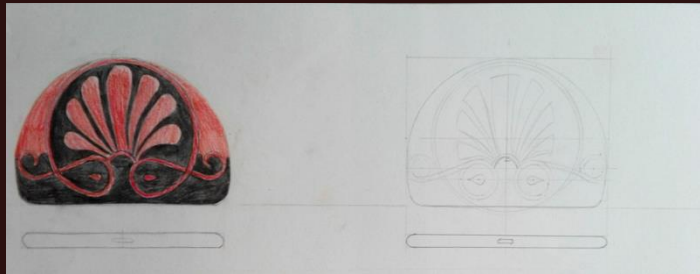

Portachiavi
 Daniele Mastrosimone classe 3^F Design

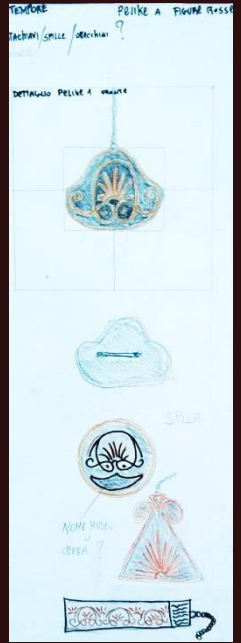



Ciondolo a croce
 Francesco Saccone classe 3^F Design

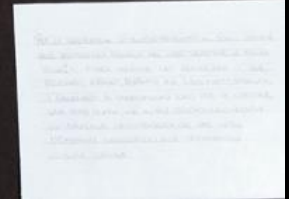
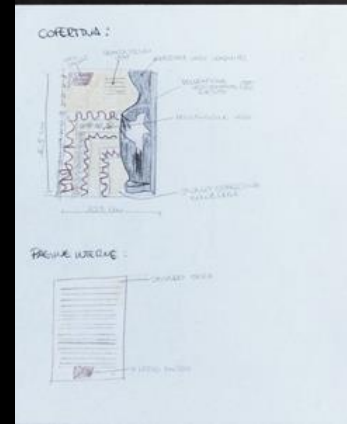
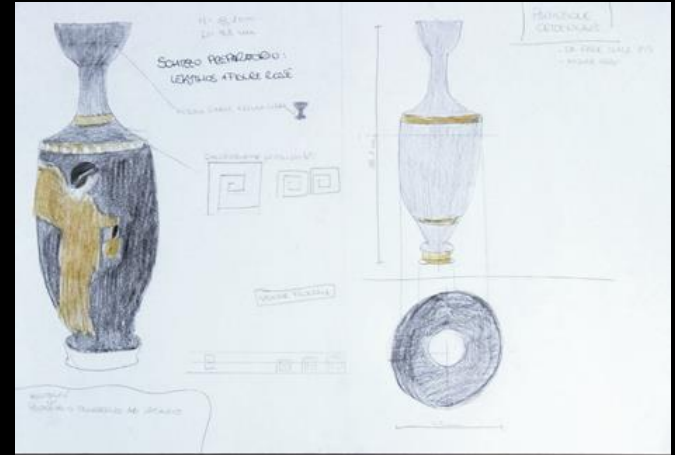

Agendina
 Sefora Palumbo classe 3^F Design



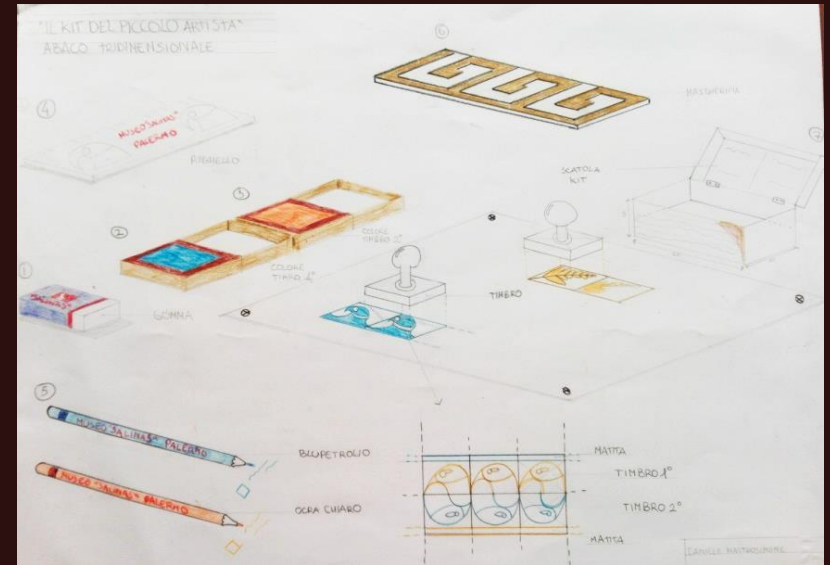

Set da tavolo
Daniele Mastrosimone classe 3^F Design

